

SWAGING GUIDELINES

and Technical
Information



SG-HT-2
01.06.2016

Focus in details®

schwer
fittings

Contents

For the most up to date version of this documentation please go to www.schwer.co.uk.

■ Fitting Interface	3
■ Maximum Working Pressures	4
■ Swage Sleeves	6
■ Working Pressure for stainless steel	23
■ Temperatures	24
■ Orientation	25
■ Hose Selection & Best Practice	26
■ Flow Capacity Nomogram	28
■ Recommended Flow Velocities	30
■ Tight Bending Radius and Tensile Loading	31
■ Twisting	32
■ Temperature	33
■ Abrasion	34
■ Measuring Hose Assemblies	35
■ Hose Assembly	36
■ Test Recommendations	40
■ Installation	43
■ Troubleshooting	44
■ Quality	48
■ Thread information	49
■ Chemical Composition	54
■ Materials	56
■ Training	58

Fitting Interface

Schwer Fittings hose connectors have two designs for the hose-to-fitting interface: **Standard**

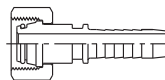

Interlock

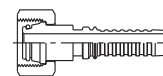

The **working pressure** of the hose assembly usually **determines** **which** of these is **most suitable**. Interlock ferrules and connectors are used for higher pressure applications with layered multi-spiral reinforced hose (**4SH, R13, R15**).

■ Hose, Ferrule and Hose Connector Suitability

Assuring the ferrule and hose type match is **very important**. However, when swaged to a different diameter, **Schwer Fittings** ferrules can be used for more than one hose type. See the table below for compatibility:

Hose Type	Standard	Ferrules	Hose Tail Design	Page
1SN	EN853	9F1-2SN	Standard	6
2SN	EN853	9F1-2SN	Standard	7
1SC	EN857	F7-8ST	Standard	8
2SC	EN857	9F1-2SN	Standard	9
1ST	EN853	F1-ST	Standard	10
2ST	EN853	F2ST4SP	Standard	11
4SP	EN856	F2ST4SP	Standard	12
R12	EN856	F2ST4SP	Standard	13
4SH	EN856	FILS*	Interlock	14
R13	EN856	FILR*	Interlock	15
R15	SAE100-R15	FILR*	Interlock	16
R16	SAE100-R16	9F1-2SN	Standard	17
PTFE Convoluted		FPTC	Standard	18
R7	ISO3949	F7-8ST	Standard	19
R8	ISO3949	F7-8ST	Standard	20
PTFE Smooth Bore		F_PTFE	Standard	21
PTFE Smooth Bore		FPT	Standard	22

* DN25 and below use the FIL ferrule for all 3 hose types

**Maximum Working Pressure – Hoses**

Hose							
Type	Standard	3/16"	1/4"	5/16"	3/8"	1/2"	5/8"
R7	ISO 3949	210	192	175	158	140	105
R8	ISO 3949	350	350	-	280	245	192
1SN	EN853	250	225	215	180	160	130
2SN	EN853	415	400	350	330	275	250
1SC	EN857	-	225	215	180	160	130
2SC	EN857	-	400	350	330	275	250
1ST	EN853	250	225	215	180	160	130
2ST	EN853	415	400	350	330	275	250
4SP	EN856	-	450	-	445	415	350
4SH	EN856	-	-	-	-	-	-
R12	EN856	-	-	-	276	276	276
R13	EN856	-	-	-	-	-	-
R15	SAE100-R15	-	-	-	-	-	-

Hose						
Type	Standard	3/4"	1"	1 1/4"	1 1/2"	2"
R7	ISO 3949	88	70	-	-	-
R8	ISO 3949	158	140	-	-	-
1SN	EN853	105	88	63	50	40
2SN	EN853	215	165	125	90	80
1SC	EN857	105	88	-	-	-
2SC	EN857	215	165	-	-	-
1ST	EN853	105	88	63	50	40
2ST	EN853	215	165	125	90	80
4SP	EN856	350	280	210	185	165
4SH	EN856	420	380	325	290	250
R12	EN856	276	276	207	172	172
R13	EN856	345	345	345	345	345
R15	SAE100-R15	414	414	414	414	414

**Max. Work. Pressure – Threads/Connections****BSPP thread (BS5200)**

BSP Parallel (60° Cone)

Metal Seal

1/8"	1/4"	3/8"	1/2"	5/8"
350	775	690	515	480
3/4"	1"	1 1/4"	1 1/2"	2"
430	345	345	345	345

UNF thread (UNF-UN)

JIC (37° Cone)

7/16"	1/2"	9/16"	3/4"	7/8"
350	350	250	250	200
1 1/16"	1 5/16"	1 5/8"	1 7/8"	2 1/2"
200	160	125	100	80

Metric Thread (Metric)

Metric Thread (24° Cone)

Light Series

6L	8L	10L	12L	15L
250	250	250	250	250
18L	22L	28L	35L	42L
160	160	100	100	100

Metric Thread (Metric)

Metric Thread (24° Cone)

Heavy Series

6S	8S	10S	12S	14S
630	630	630	630	630
16S	20S	25S	30S	38S
400	400	400	250	250

SAE Flanges (3000 Series)

SAE flange - S3000

1/2"	3/4"	1"	1 1/4"	1 1/2"
350	350	350	276	207
2"				
207				

SAE Flanges (6000 Series)

SAE Flange - S6000

1/2"	3/4"	1"	1 1/4"	1 1/2"
414	414	414	414	414
2"				
414				

Please note that the values above are the **maximum working pressures** of the threads/connections to their relevant standard, and **should not** be considered the working pressure for Schwerk connectors. Please consult the pressure ratings in the Schwerk main catalogue for pressure ratings of individual connectors.

**Swage Sleeve**

for Hose 1SN - SAE 100 R1AT - EN 853 1SN

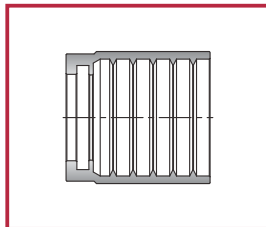
sf**1SN
R1AT**

Hose DN	Hose inch	sf-No.	Ferrule OD	Ferrule ID	Hose OD	Crimp Guide
5	3/16"	9F1SN5	19.0	13.2	11.5	15.7
6	1/4"	9F1-2SN6	23.0	15.7	13.1	18,1
8	5/16"	9F1-2SN8	24.0	17.2	15.4	19.2
10	3/8"	9F1-2SN10	26.0	19.6	17.5	20.8
12	1/2"	9F1-2SN12	29.0	23.6	20.3	23.1
16	5/8"	9F1-2SN16	33.0	26.3	23.9	27.5
20	3/4"	9F1-2SN20	37.0	30.3	28.2	31.5
25	1"	9F1-2SN25	46.0	39.2	35.3	39.1
32	1 1/4"	9F1-2SN32	59.0	49.5	44.0	48.8
40	1 1/2"	9F1-2SN40	67.0	56.0	50.3	57.0
50	2"	9F1-2SN50	80.0	68.5	64.0	70.0

■ The values provided are to be considered a guideline for the type of hose specified above!

The crimp dimensions can be affected by the manufacturing tolerances of the hose; using the tolerances below it is possible to correct for this.

Crimping tolerances:

3/16" - 3/8"	+ 0 mm / - 0.2 mm
1/2" - 2 1/2"	+ 0 mm / - 0.4 mm

**Swage Sleeve**

for Hose 2SN - SAE 100 R2AT - EN 853 2SN

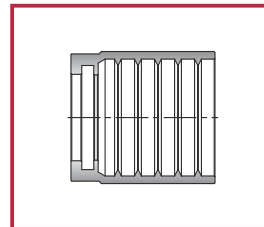
sf**2SN
R2AT**

Hose DN	Hose inch	sf-No.	Ferrule OD	Ferrule ID	Hose OD	Crimp Guide
5	3/16"	9F2SN5	20.0	14.5	13.2	16.2
6	1/4"	9F1-2SN6	23.0	15.7	14.2	18.8
8	5/16"	9F1-2SN8	24.0	17.2	16.6	19.8
10	3/8"	9F1-2SN10	26.0	19.6	18.9	22.0
12	1/2"	9F1-2SN12	29.0	23.6	22.0	24.2
16	5/8"	9F1-2SN16	33.0	26.3	25.3	28.7
20	3/4"	9F1-2SN20	37.0	30.3	29.0	32.6
25	1"	9F1-2SN25	46.0	39.2	37.0	40.5
32	1 1/4"	9F1-2SN32	59.0	49.5	47.5	51.8
40	1 1/2"	9F1-2SN40	67.0	56.0	54.3	60.0
50	2"	9F1-2SN50	80.0	68.5	66.7	72.5

■ The values provided are to be considered a guideline for the type of hose specified above!

The crimp dimensions can be affected by the manufacturing tolerances of the hose; using the tolerances below it is possible to correct for this.

Crimping tolerances:

3/16" - 3/8"	+ 0 mm / - 0.2 mm
1/2" - 2 1/2"	+ 0 mm / - 0.4 mm



Swage Sleeve

for Hose 1SC - EN 857 1SC

sf

1SC

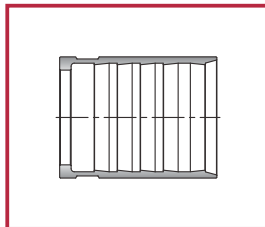

Hose DN	Hose inch	sf-No.	Ferrule OD	Ferrule ID	Hose OD	Crimp Guide
5	3/16"					
6	1/4"	F7-8ST6	18.0	14.1	13.0	15.8
8	5/16"	F7-8ST8	19.0	15.1	14.2	16.8
10	3/8"	F7-8ST10	22.0	17.7	16.5	19.0
12	1/2"	F7-8ST12	26.0	21.0	19.5	23.6
16	5/8"					
20	3/4"					
25	1"					
32	1 1/4"					
40	1 1/2"					
50	2"					

■ The values provided are to be considered a guideline for the type of hose specified above!

The crimp dimensions can be affected by the manufacturing tolerances of the hose; using the tolerances below it is possible to correct for this.

Crimping tolerances:

3/16" - 3/8"	+ 0 mm / - 0.2 mm
1/2" - 2 1/2"	+ 0 mm / - 0.4 mm



Swage Sleeve

for Hose 2SC - EN 857 2SC

sf

2SC

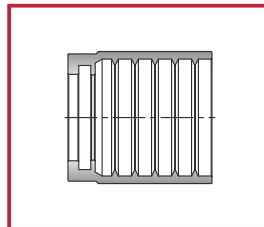

Hose DN	Hose inch	sf-No.	Ferrule OD	Ferrule ID	Hose OD	Crimp Guide
5	3/16"					
6	1/4"	9F1-2SN6	23.0	15.7	14.0	18.1
8	5/16"	9F1-2SN8	24.0	17.2	15.8	18.9
10	3/8"	9F1-2SN10	26.0	19.6	17.0	20.9
12	1/2"	9F1-2SN12	29.0	23.6	20.6	23.6
16	5/8"	9F1-2SN16	33.0	26.3	24.5	27.6
20	3/4"	9F1-2SN20	37.0	30.3	27.7	31.0
25	1"	9F1-2SN25	46.0	39.2	36.3	39.0
32	1 1/4"					
40	1 1/2"					
50	2"					

■ The values provided are to be considered a guideline for the type of hose specified above!

The crimp dimensions can be affected by the manufacturing tolerances of the hose; using the tolerances below it is possible to correct for this.

Crimping tolerances:

3/16" - 3/8"	+ 0 mm / - 0.2 mm
1/2" - 2 1/2"	+ 0 mm / - 0.4 mm



Swage Sleeve

for Hose 1ST - SAE 100 R1A - EN 853 1ST

sf

1ST

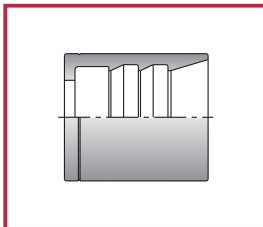

Hose DN	Hose inch	sf-No.	Ferrule OD	Ferrule ID	Skive	Crimp Guide
5	3/16"	F1ST-5	18.0	10,9	22.5	15.5
6	1/4"	F1ST-6	20.0	12.2	22.5	17.8
8	5/16"	F1ST-8	21.0	13.7	22.5	18.8
10	3/8"	F1ST-10	24.0	16.2	22.5	21.7
12	1/2"	F1ST-12	28.0	19.5	26.0	25.2
16	5/8"	F1ST-16	31.0	22.5	27.0	28.8
20	3/4"	F1ST-20	35.0	26.2	31.0	32.5
25	1"	F1ST-25	42.0	34.5	39.0	38.8
32	1 1/4"	F1ST-32	52.0	42.2	45.0	49.0
40	1 1/2"	F1ST-40	58.0	48.5	50.0	55.0
50	2"	F1ST-50	71.0	62.0	58.0	66.0

■ The values provided are to be considered a guideline for the type of hose specified above!

The crimp dimensions can be affected by the manufacturing tolerances of the hose; using the tolerances below it is possible to correct for this.

Crimping tolerances:

3/16" - 3/8"	+ 0 mm / - 0.2 mm
1/2" - 2 1/2"	+ 0 mm / - 0.4 mm



Swage Sleeve

for Hose 2ST - SAE 100 R2A - EN 853 2ST

sf

2ST

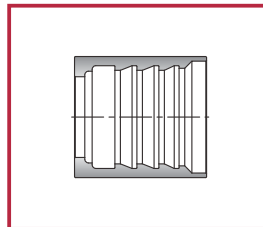

Hose DN	Hose inch	sf-No.	Ferrule OD	Ferrule ID	Skive	Crimp Guide
5	3/16"					
6	1/4"	F2ST4SP-6	22.0	15.8	21.0	17.6
8	5/16"	F2ST4SP-8	23.0	16.2	22.0	20.0
10	3/8"	F2ST4SP-10	26.0	18.5	23.0	22.5
12	1/2"	F2ST4SP-12	30.0	22.2	23.0	26.3
16	5/8"	F2ST4SP-16	33.0	25.5	26.5	29.1
20	3/4"	F2ST4SP-20	38.0	29.3	31.0	33.8
25	1"	F2ST4SP-25	46.0	35.6	38.0	42.2
32	1 1/4"	F2ST4SP-32	57.0	48.0	45.0	51.0
40	1 1/2"	F2ST4SP-40	65.0	54.3	49.0	59.0
50	2"	F2ST4SP-50	79.0	67.0	60.0	72.3

■ The values provided are to be considered a guideline for the type of hose specified above!

The crimp dimensions can be affected by the manufacturing tolerances of the hose; using the tolerances below it is possible to correct for this.

Crimping tolerances:

3/16" - 3/8"	+ 0 mm / - 0.2 mm
1/2" - 2 1/2"	+ 0 mm / - 0.4 mm



Swage Sleeve

for Hose 4SP - SAE 100 R9R - EN 856 4SP

sf

**4SP
R9R**

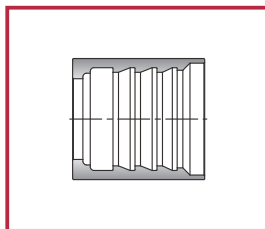

Hose DN	Hose inch	sf-No.	Ferrule OD	Ferrule ID	Skive	Crimp Guide
5	3/16"					
6	1/4"	F2ST4SP-6	22.0	15.8	21.0	18.8
8	5/16"					
10	3/8"	F2ST4SP-10	26.0	18.5	23.0	23.4
12	1/2"	F2ST4SP-12	30.0	22.2	23.5	26.7
16	5/8"	F2ST4SP-16	33.0	25.5	26.5	29.7
20	3/4"	F2ST4SP-20	38.0	29.3	31.0	34.4
25	1"	F2ST4SP-25	46.0	35.6	38.0	42.2
32	1 1/4"	F2ST4SP-32	57.0	48.0	45.0	51.7
40	1 1/2"	F2ST4SP-40	65.0	54.3	49.0	59.3
50	2"	F2ST4SP-50	79.0	67.0	60.0	73.0

■ The values provided are to be considered a guideline for the type of hose specified above!

The crimp dimensions can be affected by the manufacturing tolerances of the hose; using the tolerances below it is possible to correct for this.

Crimping tolerances:

3/16" - 3/8"	+ 0 mm / - 0.2 mm
1/2" - 2 1/2"	+ 0 mm / - 0.4 mm



Swage Sleeve

for Hose R 12 - SAE 100 R12 - EN 856 R 12

sf

R12

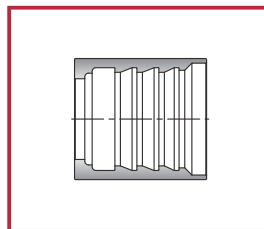

Hose DN	Hose inch	sf-No.	Ferrule OD	Ferrule ID	ext. Skive	Crimp Guide
5	3/16"					
6	1/4"					
8	5/16"					
10	3/8"	F2ST4SP-10	26.0	18.5	23.0	23.3
12	1/2"	F2ST4SP-12	30.0	22.2	23.5	26.7
16	5/8"	F2ST4SP-16	33.0	25.5	27.0	29.3
20	3/4"	F2ST4SP-20	38.0	29.3	31.0	34.4
25	1"	F2ST4SP-25	46.0	35.6	38.0	42.2
32	1 1/4"	F2ST4SP-32	57.0	48.0	45.0	50.5
40	1 1/2"	F2ST4SP-40	65.0	54.3	49.0	58.8

■ The values provided are to be considered a guideline for the type of hose specified above!

The crimp dimensions can be affected by the manufacturing tolerances of the hose; using the tolerances below it is possible to correct for this.

Crimping tolerances:

3/16" - 3/8"	+ 0 mm / - 0.2 mm
1/2" - 2 1/2"	+ 0 mm / - 0.4 mm

**Swage Sleeve**

for Hose 4SH - EN 856 4SH

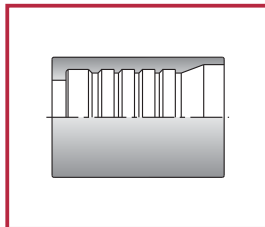
sf**4SH**

Hose DN	Hose inch	sf-No.	Ferrule OD	Ferrule ID	int. Skive	ext. Skive	Crimp Guide
5	3/16"						
6	1/4"						
8	5/16"						
10	3/8"						
12	1/2"						
16	5/8"						
20	3/4"	FIL-20	40.0	30.0	17.0	52.0	35.5
25	1"	FIL-25	47.0	37.0	18.0	57.0	42.0
32	1 1/4"	FILS-32	56.0	43.0	21.0	64.0	50.0
40	1 1/2"	FILS-40	63.0	48.6	24.0	77.0	57.0
50	2"	FILS-50	80.0	64.0	26.0	82.0	74.0

- The values provided are to be considered a guideline for the type of hose specified above!

The crimp dimensions can be affected by the manufacturing tolerances of the hose; using the tolerances below it is possible to correct for this.

Crimping tolerances:

3/16" - 3/8"	+ 0 mm / - 0.2 mm
1/2" - 2 1/2"	+ 0 mm / - 0.4 mm

**Swage Sleeve**

for Hose R 13 - SAE 100 R 13 - EN 856 R 13

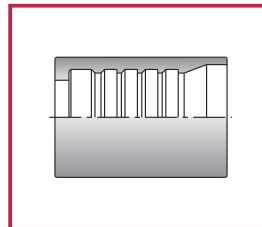
sf**R13**

Hose DN	Hose inch	sf-No.	Ferrule OD	Ferrule ID	Hose OD	int. Skive	ext. Skive	Crimp Guide
5	3/16"							
6	1/4"							
8	5/16"							
10	3/8"							
12	1/2"							
16	5/8"							
20	3/4"	FIL-20	40.0	30.0	33.1	17.0	52.0	36.0
25	1"	FIL-25	47.0	37.0	38.3	18.0	57.0	42.5
32	1 1/4"	FILR-32	61.0	48.0	49.7	21.0	64.0	55.0
40	1 1/2"	FILR-40	70.2	55.6	57.2	24.0	77.0	64.0
50	2"	FILR-50	85.0	69.6	70.8	26.0	82.0	79.0

- The values provided are to be considered a guideline for the type of hose specified above!

The crimp dimensions can be affected by the manufacturing tolerances of the hose; using the tolerances below it is possible to correct for this.

Crimping tolerances:

3/16" - 3/8"	+ 0 mm / - 0.2 mm
1/2" - 2 1/2"	+ 0 mm / - 0.4 mm



Swage Sleeve

for Hose R 15 - SAE 100 R 15

sf

R15

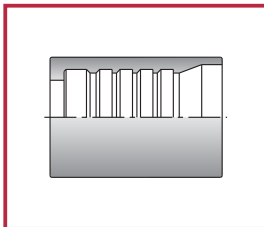

Hose DN	Hose inch	sf-No.	Ferrule OD	Ferrule ID	int. Skive	ext. Skive	Crimp Guide
5	3/16"						
6	1/4"						
8	5/16"						
10	3/8"						
12	1/2"						
16	5/8"						
20	3/4"	FIL-20	40.0	30.0	17.0	52.0	35.5
25	1"	FIL-25	47.0	37.0	18.0	57.0	42.0
32	1 1/4"	FILR-32	61.0	48.0	21.0	64.0	54.5
40	1 1/2"	FILR-40	70.0	55.6	24.0	77.0	64.0
50	2"						

- The values provided are to be considered a guideline for the type of hose specified above!

The crimp dimensions can be affected by the manufacturing tolerances of the hose; using the tolerances below it is possible to correct for this.

Crimping tolerances:

3/16" - 3/8"	+ 0 mm / - 0.2 mm
1/2" - 2 1/2"	+ 0 mm / - 0.4 mm



Swage Sleeve

for Hose R 16 - SAE 100 R 16

sf

R16

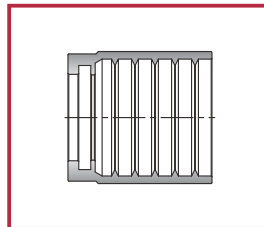

Hose DN	Hose inch	sf-No.	Ferrule OD	Ferrule ID	Hose OD	Crimp Guide
5	3/16"					
6	1/4"	9F1-2SN6	23.0	15.7	12.3	17.5
8	5/16"					
10	3/8"	9F1-2SN10	26.0	19.6	16.8	20.5
12	1/2"	9F1-2SN12	29.0	23.6	20.7	23.9
16	5/8"					
20	3/4"					
25	1"					
32	1 1/4"					
40	1 1/2"					
50	2"					

- The values provided are to be considered a guideline for the type of hose specified above!

The crimp dimensions can be affected by the manufacturing tolerances of the hose; using the tolerances below it is possible to correct for this.

Crimping tolerances:

3/16" - 3/8"	+ 0 mm / - 0.2 mm
1/2" - 2 1/2"	+ 0 mm / - 0.4 mm

Swage Sleeve

Swage Sleeve

PTFE Convoluted

for Hose R 7 - SAE 100 R 7

sf

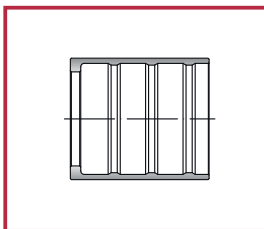
PTFE
convoluted

Hose DN	Hose inch	sf-No.	Ferrule OD	Ferrule ID	Crimp Guide
5	3/16"				
6	1/4"	FPTC-6	16.0	12.5	12.2
8	5/16"	FPTC-8	17.0	13.0	14.0
10	3/8"	FPTC-10	21.5	17.7	16.8
12	1/2"	FPTC-12	25.0	21.0	20.2
16	5/8"	FPTC-16	29.0	24.5	24.0
20	3/4"	FPTC-20	34.0	30.0	26.3
25	1"	FPTC-25	40.0	34.6	34.0
32	1 1/4"	FPTC-32	46.0	42.0	39.0
40	1 1/2"	FPTC-40	55.0	49.0	48.2
50	2"	FPTC-50	69.0	63.2	60.2

■ The values provided are to be considered a guideline for the type of hose specified above!

The crimp dimensions can be affected by the manufacturing tolerances of the hose; using the tolerances below it is possible to correct for this.

Crimping tolerances:

3/16" - 3/8" + 0 mm / - 0.2 mm

1/2" - 2 1/2" + 0 mm / - 0.4 mm

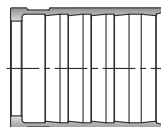

sf

R7

Hose DN	Hose inch	sf-No.	Ferrule OD	Ferrule ID	Hose OD	Crimp Guide
4	1/8"	F7-8ST-4	13.0	8.9	AOR*	AOR*
5	3/16"	F7-8ST-5	14.0	11.4	9.6	11.2
6	1/4"	F7-8ST-6	18.0	13.8	12.0	14.6
8	5/16"	F7-8ST-8	19.0	14.8	14.3	16.5
10	3/8"	F7-8ST-10	22.0	17.7	16.0	18.6
12	1/2"	F7-8ST-12	26.0	21.0	20.3	23.0
16	5/8"	F7-8ST-16	29.0	24.5	24.3	26.0
20	3/4"	F7-8ST-20	31.5	27.5	27.2	28.4
25	1"	F7-8ST-25	40.0	34.6	34.5	37.0
32	1 1/4"					
40	1 1/2"					
50	2"					

■ The values provided are to be considered a guideline for the type of hose specified above!

The crimp dimensions can be affected by the manufacturing tolerances of the hose; using the tolerances below it is possible to correct for this.

Crimping tolerances:

3/16" - 3/8" + 0 mm / - 0.2 mm

1/2" - 2 1/2" + 0 mm / - 0.4 mm *AOR – available on request.

**Swage Sleeve**

for Hose R 8 - SAE 100 R 8

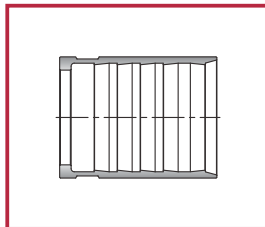
sf**R8**

Hose DN	Hose inch	sf-No.	Ferrule OD	Ferrule ID	Hose OD	Crimp Guide
4	1/8"	F7-8ST-4	13.0	8.9	AOR*	AOR*
5	3/16"	F7-8ST-5	14.0	11.4	9.4	11.1
6	1/4"	F7-8ST-6	18.0	13.8	11.5	14.3
8	5/16"	F7-8ST-8	19.0	14.8	13.3	15.7
10	3/8"	F7-8ST-10	22.0	17.7	15.5	18.3
12	1/2"	F7-8ST-12	26.0	21.0	19.9	23.0
16	5/8"	F7-8ST-16	29.0	AOR	23.4	26.0
20	3/4"	F7-8ST-20	31.5	27.5	27.0	29.0
25	1"	F7-8ST-25	40.0	34.6	34.2	37.0
32	1 1/4"					
40	1 1/2"					
50	2"					

■ The values provided are to be considered a guideline for the type of hose specified above!

The crimp dimensions can be affected by the manufacturing tolerances of the hose; using the tolerances below it is possible to correct for this.

Crimping tolerances:

3/16" - 3/8" + 0 mm / - 0.2 mm
 1/2" - 2 1/2" + 0 mm / - 0.4 mm *AOR - available on request.

**Swage Sleeve**

PTFE Smooth Bore

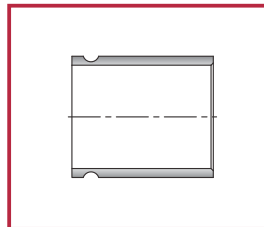
**sf****PTFE**

Hose DN	Hose inch	sf-No.	Ferrule OD	Ferrule ID	Hose OD	Crimp Guide
5	3/16"					
6	1/4"	F6PTFE	14.1	11.1		11.9
8	5/16"					
10	3/8"	F10PTFE	19.0	15.1		16.0
12	1/2"	F12PTFE	22.5	18.5	18.5	18.9
16	5/8"	F16PTFE	27.0	23.1	23.1	22.8
20	3/4"	F20PTFE	28.8	24.8	24.8	26.2
25	1"	F25PTFE-7	38.0	33.9	33.9	32.7

■ The values provided are to be considered a guideline for the type of hose specified above!

The crimp dimensions can be affected by the manufacturing tolerances of the hose; using the tolerances below it is possible to correct for this.

Crimping tolerances:

3/16" - 3/8" + 0 mm / - 0.2 mm
 1/2" - 2 1/2" + 0 mm / - 0.4 mm



Swage Sleeve



Working Pressure for stainless steel

PTFE Smooth Bore

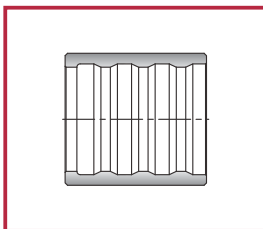
SF**FPT**

Hose DN	Hose inch	sf-No.	Ferrule OD	Hose OD	Crimp Guide
5	3/16"	FPT5	14.0		11.5
6	1/4"	FPT6	15.0	11.1	13.0
8	5/16"	FPT8	17.0		13.8
10	3/8"	FPT10	18.0	15.1	15.5
12	1/2"	FPT12	24.0	18.5	20.5
16	5/8"	FPT16	28.0	23.1	23.5
20	3/4"	FPT20	30.0	24.8	27.0
25	1"	FPT25	36.0	33.9	34.0

- The values provided are to be considered a guideline for the type of hose specified above!

The crimp dimensions can be affected by the manufacturing tolerances of the hose; using the tolerances below it is possible to correct for this.

Crimping tolerances:

3/16" – 3/8" + 0 mm / - 0.2 mm

1/2" – 2 1/2" + 0 mm / - 0.4 mm

Working Pressure for stainless steel

Attention: The system's maximum working pressure is obtained by finding the lowest maximum working pressure of all components in the system. Please note that temperature can affect the working pressure of components.

For couplings with inside or outside threads, **compare** the **maximum working pressure of the thread** with that of the **tube** used. The lowest value is the maximum working pressure of the system.

The **safety factor** for couplings on the tube connection is 4:1, 2.5:1 for the threaded connections, and 1.5:1 for the tubes. Due to the greater wall thickness, threaded connections with outside threads offer a higher maximum working pressure than those with the equivalent inside thread.

Couplings with JIC-connection, o-ring sealing, or SAE/ MS connections only offer a lower maximum working pressure. **For applications at the extremes** of the recommended working pressures / temperature, it is recommended to consult our technical department before designing or assembling an installation.

Temperatures

Temperatures

The maximum working pressures in the charts refer to a temperature of **25°C to 50°C**. For higher temperatures, please multiply the PN by the factor in this table of temperature related working pressures.

This chart is to be considered as a guideline only, and is **subject to change**.

We cannot guarantee our fittings under **extreme temperatures**. Maximum working pressure depends on the **individual use and the medium**. Please contact our technical department to obtain information of the maximum working pressure with your application.

Temp.	Factor
25° C	1,00
38° C	1,00
100° C	1,00
149° C	1,00
200° C	0,97
250° C	0,90
306° C	0,85
350° C	0,82
400° C	0,80
450° C	0,78
500° C	0,77
600° C	0,62

Orientation

Orientation

If a hose assembly has **2 angled end connectors** the **orientation** becomes **very important**. If orientated **incorrectly** the connector will be at the **wrong** angle and will prevent correct assembly.

To get the orientation correct: **one fitting should be facing 0° (straight upwards)** and the other should be **turned clockwise to the desired orientation** (e.g. 180°). **Never twist fittings a swaged hose assembly!** Turning the fittings once crimped is **highly likely to cause a failure**.

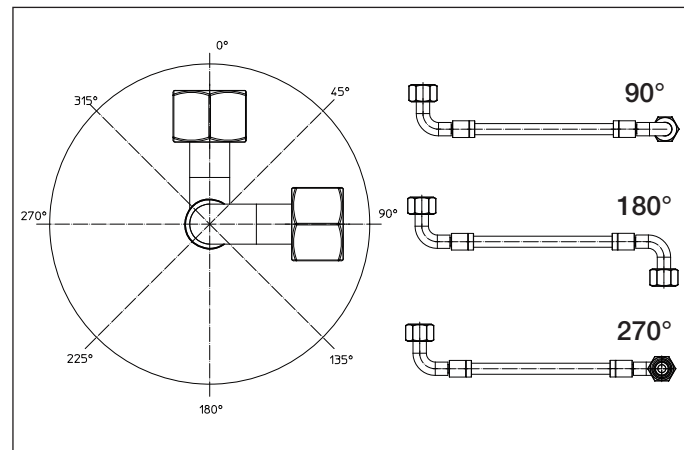

Figure 1: An illustration showing angular orientation of hose connectors



Hose Selection & Best Practice

■ Hose Selection & Best Practice

Selecting the correct type of hose for any application is vital. Determining which hose is most suitable means considering many factors such as: operating temperature, ambient temperature, the medium running through the line, and dynamic pressure. This list is not exhaustive.

Correctly sizing the hydraulic lines is also an **important** consideration. To achieve a high level of efficiency within the hydraulic circuit, **pressure losses need to be kept to a minimum**. Pressure loss depends on the following factors:

- Flow Velocity:** This increases as the area of the internal bore decreases.
- Length:** The length of the hose will affect the area of the internal bore, creating a larger area for friction to occur, causing a drop in pressure.
- Viscosity:** As viscosity increases, pressure also increases.
- Density:** An increase in density of the medium will cause an increase in pressure.
- Type of Flow:** If there is turbulent flow within the line, molecules within the medium start to collide and hinder each other, causing friction and a drop in pressure. Laminar flow is ideal as the medium moves along the line in uniform layers, without the particles disturbing each other.



Hose Selection & Best Practice

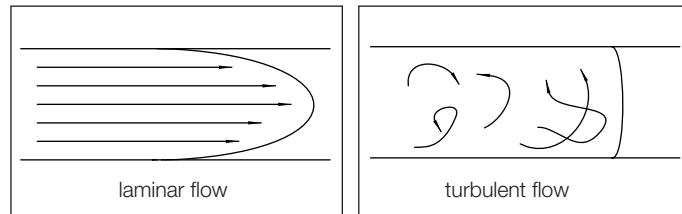

Figure 2: A diagram representing the differences in the movement of molecules with laminar and turbulent flow

To determine what kind of flow is present the following equation can be used:

$$Re = \frac{v \times d}{\mu}$$

v = velocity (m/s)
 d = flow line internal diameter (m)
 μ = kinematic viscosity (m²/s)
 Re = Reynold's Number

Laminar flow occurs when Re is below 2300. When the Re value is above 2300 the flow will become turbulent and a pressure drop will be observed.

Flow Capacity Nomogram

Flow Capacity Nomogram

Using the chart below it is possible to determine either the hose bore, flow rate or flow velocity. For example, with values for flow rate and flow velocity it is possible to get a suitable hose bore for use in a hydraulic line. This is invaluable when trying to prevent pressure drops within a hydraulic line.

Use the following steps to attain the hose bore using the nomogram:

- 1) Find the **2 known values** for flow rate and flow velocity.
- 2) Place a **straight edge across the 2 values** and the **3rd value** can be determined by where the **line intersects**.
- 3) **Round up** to the **higher value** when determining the hose bore (e.g. if the hose bore value is above 3/4" but below 1" this will be rounded to a 1" hydraulic hose for that particular line).

Flow Capacity Nomogram

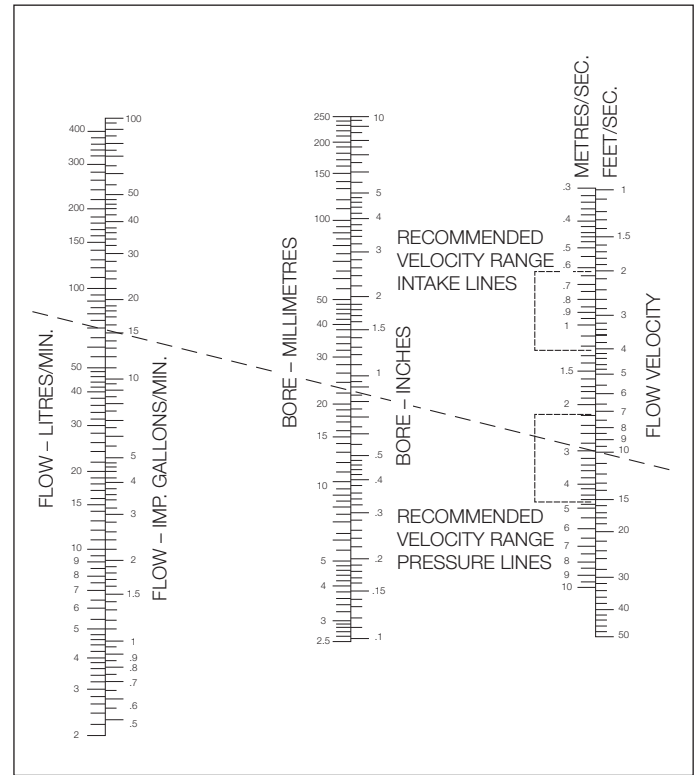

Figure 3: A fluid capacity nomogram

Recommended Flow Velocities

Recommended Flow Velocities

Suction Lines:	0.5 - 1.2 m/s	1.6 - 4 feet/s
Return Lines:	2.0 - 3.0 m/s	6.5 - 10 feet/s
Pressure Lines:	4.0 - 7.5 m/s	13.0 - 25 feet/s

Hose Routing

To **prevent premature failure** of the hose assembly, **correct routing is essential**. Kinking, twisting, abrasion or high temperatures are likely to cause **unnecessary stress** which will shorten the life expectancy of the hose. **Correctly** routing the hoses can remove these stresses and **extend the life of the hose assembly significantly**.

Tight Bending Radius and Tensile Loading

Tight Bending Radius and Tensile Loading

When deciding on the **optimum way** to route a hose, the minimum bend radius is the **most important thing** to keep in mind. If the hose is bent at an angle which reduces the bending radius below the minimum, this will **greatly reduce the life expectancy** of the hose. 90° and 45° hose tail fittings are the **simplest way** of removing tight angles between 2 connections. Increasing the length of the hose to create a larger curve can also solve some of these issues.

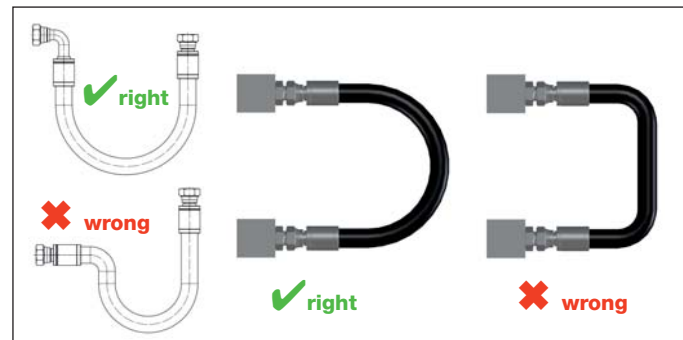

Figure 4: An example of how 90 degree fittings (left) and increasing the hose length (right) can remove tight bending radii and prevent premature failure

It is **always good practice** to make sure that the load exerted on a hose or fitting is not too high; this is called **tensile loading** and **can cause failures** at the points of connection. **It is best to keep in mind** that the load can come from the weight of the hose and the medium within it, as well as any external load applied to the hose.



Twisting

■ Twisting

Twisting the hose can also become an issue on moving parts. **It is very important** to make sure any **movement works along the hose's length** rather than across the hose's outside diameter (see figure 5). If the **hose twists**, the **inside bore can be reduced** which will reduce the throughput and is **likely to cause damage to the assembly** or the machinery. This action can also **twist and damage** the internal reinforcement of the hose. The use of **strategically placed** clamps can **help prevent** the hose moving in more than one plain.

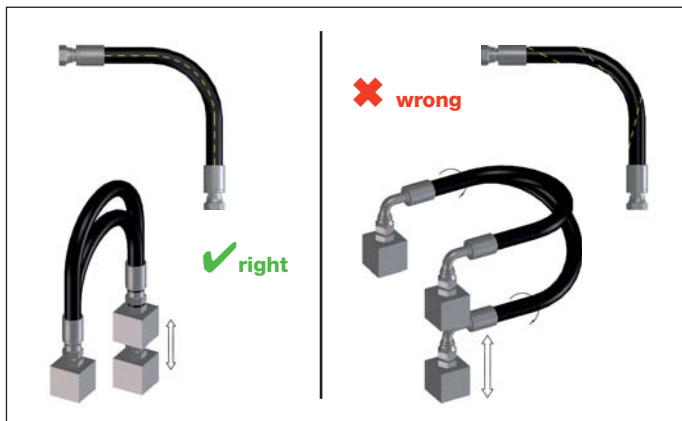

Figure 5: The diagram on the right shows the incorrect way to route the hose. This diagram shows the hose being twisted across its diameter which can force the braid or spiral reinforcement apart or reduce the bore size. The diagram on the left is the correct way to route the hose as the movement goes along the hose's length and will prevent the hose twisting.



Temperature

■ Temperature

It is also **good practice** to make sure the hose assemblies are **shielded from high temperatures**. If the hose is placed on a heated surface with an **unsuitable cover**, it is likely to become hard and brittle. **Cracks** will form along the surface of the hose and will reveal the wire reinforcement beneath. This will cause corrosion of reinforcement and **failure can occur**.



Source: BFPA

Figure 6: A hose with a cracked outer cover due to being exposed to heat 20° C higher than its maximum working

Abrasion

■ Abrasion

Another issue to **think about** is **abrasion**. **Making sure** the hose is not rubbing against an edge or even other hoses is an **important consideration**.

Using 90° and 45° hose fittings or reducing/increasing the length of the hose can solve most of these issues. When many hoses are bundled up they are likely to rub together and increase the likelihood of failure, however using hose spiral wrap when creating kits will prevent abrasion and increase the life expectancy of the hose. However, one of the disadvantages of spiral wrap is it is quite labour intensive on longer hose assemblies. Clamping the hoses in place is also an excellent way to prevent abrasion, if the clamps do not interfere with the movement of the hose. Another way of preventing abrasive damage is to use a hose with a more resistant cover.

Hoses with a UHMWPE cover for example are very resistant to abrasion; these are normally used in mining applications where this kind of protection is essential.



Source: BFFA

Figure 7: Hydraulic hose with its protective cover removed by abrasion

Measuring Hose Assemblies

■ Measuring Hose Assemblies

The length of a hose assembly is usually ascertained by measuring the equipment or the associated drawings.

The **bending radius should always be taken into account** when deciding the hose assembly length.

The length of a hose assembly is **always taken from the end of the sealing edge**, or in the **case of 45° and 90° fittings the centre of the curve**.

To determine the amount of hose needed, the **cut off factor** must be removed.

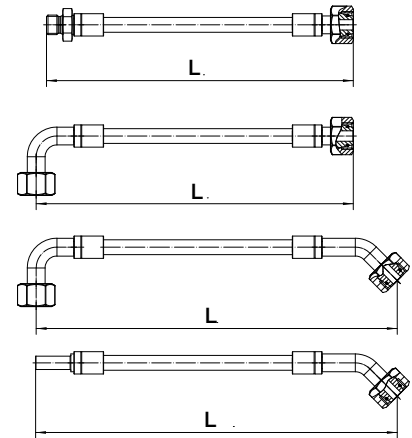

Figure 8: An illustration showing how to measure the length of hose assemblies correctly

This is the distance from the seat of the hose tail to the seal (value C). Removing this value from the overall length of the hose assembly will leave the exact length the hose should be cut to.

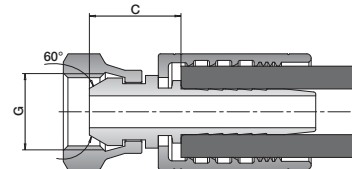

Figure 9: A diagram showing the cut off factor of a hose assembly



Hose Assembly

Once the type of hose has been chosen, the correct length has been determined and the correct orientation has been found, it is possible to begin assembly. Below is a rough guide, however assembly should always be performed by a competent person who has received sufficient training.

■ Cutting

Measure out the correct hose length. This will be the hose assembly length minus the cut off value mentioned above (Figure 9). **Using** a flat table with a 90° corner will make the **hose sit flat** and will make it easier to measure, and then use a white permanent pen to mark the length. Once you have marked the hose, cut the hose using a designated hose cutter, **circular saw or hacksaw**. Check that the hose is **cut square ($\pm 5^\circ$)** and **remove** as much contamination as possible using a foam pellet or compressed air.



Figure 10: A photograph showing how to cut hydraulic hose using a dedicated hose cutter.



Hose Assembly

■ Skiving

If the hose requires **external skiving**, the cover of the hose should be removed down to the first layer of metal reinforcement on the outside of the hose. With **internal skiving**, the rubber should be removed on the inside layer to the first internal metal reinforcement.

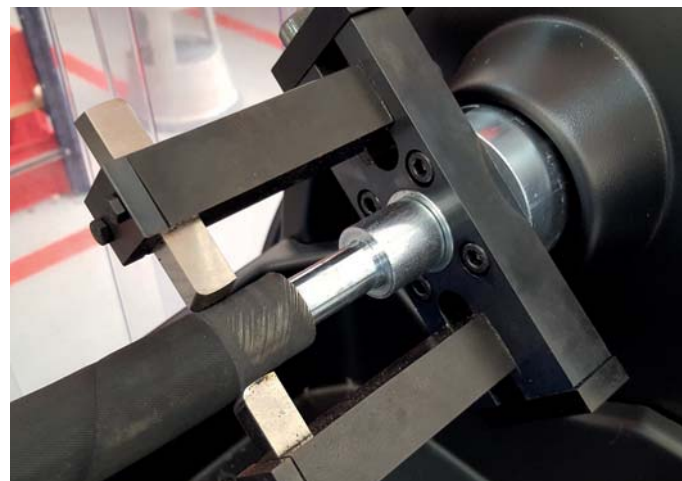

Figure 11: A skiving machine removing the outside cover of a 4SH hydraulic hose.



Hose Assembly

■ Swaging

Before swaging can occur the ferrule **must be placed** all the way onto the hose and the hose tail **must be fully** inserted into the hose. A rubber mallet can be used to make sure the hose tail is fully inserted.

To help insertion a lubricant such as P80 can be used; **when this particular lubricant dries** it will not become slippery again even in the presence of water. This is **obviously important** when used with hoses. The next step is to **make sure** the orientation is correct (see section above). **If all the steps are complete** the hose can be swaged down to the crimp dimension given by the fittings manufacturer.

The crimp dimensions for Schwer stainless steel fittings are given in this booklet. Due to the tolerances involved with the hose and the fittings themselves these values should not be taken at face value. To get a guaranteed value a **collapse gauge** should be used in conjunction with the crimp diameters.



Figure 12: A technician swaging a hydraulic hose assembly using a swaging machine.



Hose Assembly

A collapse gauge has a **GO** and **NO-GO** and should fit through the hose tail unrestricted with the GO gauge and should not pass through the bore of the hose tail with the NO-GO. This will determine whether the "insert bore collapse" is sufficient. Use a Vernier to check the outside diameter of the ferrule to see if it has been swaged to the correct value.

■ Testing

Testing is not always essential for new hose assemblies and is often based on customer preference or application. If a hose has been **stored for a long period of time** they should be tested to ascertain whether the hoses are still in an acceptable condition (Consult the tables on page 40 - 42 for details). For hydraulic hose assemblies **ISO 1402** outlines the methodology for **proof testing** and **burst testing**. Hydraulic hoses for example are proof tested at **2x maximum working** and are held for **30 – 60 seconds**. The rate of pressure increase must also be constant. As hydraulic hoses have an inside diameter of up to 50 mm the proof test pressure must be reached in between 30 – 60 seconds.



Figure 13: A photograph showing 3 hoses attached to a hydrostatic test bench before testing.



Test Recommendations

■ Test Recommendations for Stored Equipment

Hoses that are stored in extreme conditions for over 1 year should be tested to the same criteria as 3 to 5 year hoses. Hose assemblies on stored equipment should be filled with the medium that will run through them during operation.

Test Recommendations for Hydraulic Hose Assemblies are sourced with permission from BFFA/P47 GUIDELINES FOR THE USE OF HYDRAULIC FLUID POWER HOSE AND HOSE ASSEMBLIES

Age Recommendations

Up to 3 years Use without further testing

3 to 5 years A pressure test at 1.5x the working pressure needs to be performed on all hoses and selected samples should be burst tested.

Over 5 years These should be destroyed.

■ Test Recommendations for Thermoplastic Hose

Age Recommendations

Up to 3 years Use without further testing

5 to 8 years A pressure test at 1.5x the working pressure needs to be performed on all hoses and selected samples should be burst tested.

8 to 12 years Selected samples should be subjected to burst tests, cold bend tests, electrical tests and impulse tests. All hoses should be tested to 1.5x working pressure.

Over 12 years These should be destroyed.



Test Recommendations

■ Test Recommendations for Thermoplastic Hose Assemblies

Age Recommendations

Up to 3 years Use without further testing

5 to 8 years A pressure test at 1.5x the working pressure needs to be performed on all hoses and selected samples should be burst tested.

8 to 12 years Selected samples should be subjected to burst tests, cold bend tests, electrical tests and impulse tests. All hoses should be tested to 1.5x working pressure.

Over 12 years These should be destroyed.

■ Test Recommendations for Hydraulic Hoses

Age Recommendations

Up to 3 years Use without further testing

3 to 5 years A pressure test at 1.5x the working pressure needs to be performed on all hoses.

5 to 8 years Selected samples should be subjected to burst tests, cold bend tests, electrical tests and impulse tests. All hoses should be tested to 1.5x working pressure.

Over 8 years These should be destroyed.



Test Recommendations

■ Test Recommendations for Hydraulic Hose Assemblies

Age	Recommendations
Up to 3 years	Use without further testing
3 to 5 years	A pressure test at 1.5x the working pressure needs to be performed on all hoses and selected samples should be burst tested.
5 to 8 years	Selected samples should be subjected to burst tests, cold bend tests, electrical tests and impulse tests. All hoses should be tested to 1.5x working pressure.
Over 8 years	These should be destroyed.



Installation

■ Installation

When installing any hose assembly it is **essential** that the connections are **free from burrs, dirt or any other contaminants**. As mentioned above contamination **can cause serious problems** in a hydraulic system as well interfering with the threaded connections. It is best to also make sure that connectors are not overtightened; as this can cause damage to the threads or the sealing face of the fittings.

For the assembly of Schwer stainless connectors, **5GP** lubricant **must be applied** to the **threads and cones** of the connectors; this is due to stainless steel fittings being more prone to cold welding (galling). When stainless steel is forced together (such as when threads are tightened) the passive oxide layer of the steel is removed. This exposes the reactive layers underneath and it does not require any additional activation energy to cold weld the steel together.

This can only occur if the materials are sufficiently similar. Galling between 304 stainless steel and 316 stainless steel for example will be significantly less than if two identical grades are forced together.



Figure 13: Mo-5GP lubricant



Troubleshooting

Issue ■ Possible Causes ➤ Solutions

End connector removes itself from the end of the hose

- Hose and/or fittings may be unsuitable for the application
 - Replace fittings and/or hose with more suitable alternatives e.g. higher pressure hose fittings (4SP, 4SH etc.)
- Hose may be too short, twisted or that the radius of the bend is lower than the minimum bending radius.
 - Increase the hose length and make sure no twisting occurs during operation.
- The hose may be crimped to the wrong swaging dimension.
 - Check the assembly is being performed correctly. Make sure the crimping diameter is correct.
- Hose may be incorrectly assembled or crimped incorrectly.
 - Check assembly is being performed correctly.
- Skiving of the hose may be required or the skiving may have been performed incorrectly.
 - Check the specifications of the hose fittings/hose and whether skiving is required. Also find a skiving diameter and length from the manufacturer.



Troubleshooting

Issue ■ Possible Causes ➤ Solutions

Hose bursts on the outer surface of a bend

- It is most likely the hose went below the minimum bending radius and therefore the reinforced inner braid or spiral layer has opened, causing a weak point in the hose structure.
 - Increase the length of the hose assembly, use 90° or 45° fittings to remove the tight bends or alternatively use a more compact hose with a lower minimum bending radius (make sure the new hose is suitable for the requirements of the system).
- The pressure increased past the minimum burst pressure of the hose.
 - Replace the hose with one more suitable for the application or reduce the pressure within the system.

Hose liner deteriorates or swells, throughput is reduced or leaks occur.

- Hose liner is incompatible with the medium inside the hose.
 - Change the type of hose to one more suitable for the medium within the hose.
- Temperature may be outside the tolerance of the hose. This may be the medium running through the hose or an environmental factor.
 - Change the type of hose to one more suitable for the temperature of the medium. If it is caused by the temperature of the surrounding environment then a hose with a more temperature resistant cover may be used.



Troubleshooting

Issue ■ Possible Causes ➤ Solutions

Hose has burst and the wire reinforcement is rusted at the burst point

- Hose cover has been broken by trauma or abrasion.
 - Remove any routing issues that may cause trauma or abrasion. Possibly use a hose with a more resilient cover. Use some spiral wrap or other hose protection.
- Hose cover has been broken by extreme temperatures or chemical attack.
 - Choose a hose more suitable for the temperature and/or volatility of the medium
- Hose cover has been broken by improper skiving of the hose
 - Check that skiving is being performed correctly and to the right dimensions.
- Hose cover has been broken by gases trapped between the layers.
 - If gas is building up inside the cover, the hose may need to be perforated (pin pricked). This lets the gas escape and prevents a pressure build up under the cover, which will eventually cause it to burst.



Troubleshooting

Issue ■ Possible Causes ➤ Solutions

Leaking occurs at the threaded connector

- Sealing surface or thread may be affected by contamination.
 - Clean the connectors, and make sure no damage has occurred to the threads or the sealing cones.
- The connector may be loose, or conversely the connector may be over tightened
 - Tighten the connectors or replace them as necessary
- The o-ring or soft seal may have deteriorated.
 - Replace the seals if necessary.
- It may also be worthwhile to check that the sealing surfaces match. It could be possible that the threads match, but a sealing cone may not be present.
 - Change the adapters to a matching connection.

Quality

■ Laser-marked Test Report Number

Schwer Fittings focuses on quality and precision when it comes to stainless steel components. Therefore every individual item **is laser marked with a traceable number** which can be used **to find every detail** about its production. We can therefore supply **3.1 material certificates** many years after the item has been purchased.

We also take quality control very seriously; during production components are continuously checked using tactile and optical tests, test reports are completed before final assembly and items are marked with the "sf", material description and a test report number.

Figure 14:
Sample material certificate (below)
and laser numbers (left)



■ Labeling



■ Packaging



Thread information

BSP

Abbreviation: **G**
 Description: ISO 228-G 1/2"
 Type: **parallel inside**
 Uses: pipe fittings,
 not sealing on the thread

ISO 228-G 1/2" A
parallel outside (tol. class A)

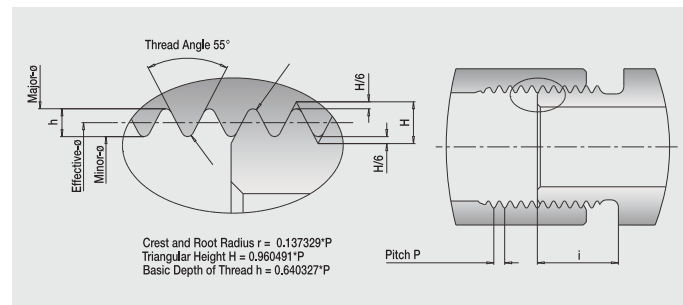

Inside G-thread

Nominal size	-54°C +20°C		core ø
	bar	psi	
G 1/8"	440	6.380	8,566
G 1/4"	450	6.525	11,445
G 3/8"	360	5.220	14,950
G 1/2"	330	4.785	18,631
G 3/4"	320	4.640	24,117
G 1"	300	4.350	30,291
G 1 1/4"	350	5.075	38,952
G 1 1/2"	310	4.495	44,845

Outside G-thread CS, RS, ES

Nominal size	-54°C +20°C		outside ø
	bar	psi	
G 1/8"	690	10.005	9,728
G 1/4"	550	7.975	13,157
G 3/8"	540	7.830	16,662
G 1/2"	530	7.685	20,955
G 3/4"	500	7.250	26,441
G 1"	370	5.365	33,249
G 1 1/4"	410	5.945	41,910
G 1 1/2"	340	4.930	47,803

Thread information

BSP

Abbreviation: **Rp, Rc**
 Description: ISO 7/1
 Type: **Parallel inside**
R Tapered outside (taper 1:16)
 Uses: Pipe fittings, for threaded pipe and fittings, sealing in the thread with sealing material

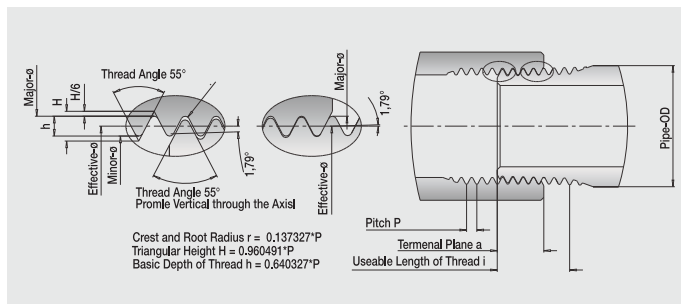

Inside Rp-thread

Nominal size	-54°C +20°C bar	psi	core ø
Rp 1/16"	460	6.670	6,561
Rp 1/8"	440	6.380	8,566
Rp 1/4"	450	6.525	11,445
Rp 3/8"	360	5.220	14,950
Rp 1/2"	330	4.785	18,631
Rp 3/4"	320	4.640	24,117
Rp 1"	300	4.350	30,291
Rp 1 1/4"	350	5.075	38,952
Rp 1 1/2"	310	4.495	44,845
Rp 2"	270	3.915	56,656

Outside R-thread

Nominal size	-54°C +20°C bar	psi	outside ø
R 1/16"	760	10.020	7,723
R 1/8"	690	10.005	9,728
R 1/4"	550	7.975	13,157
R 3/8"	540	7.830	16,662
R 1/2"	530	7.685	20,955
R 3/4"	500	7.250	26,441
R 1"	370	5.365	33,249
R 1 1/4"	410	5.945	41,910
R 1 1/2"	340	4.930	47,803
R 2"	270	3.915	59,614

Thread information

American tapered thread

Abbreviation: **NPT**
 Description: to ANSI/ASME B 1.20.1-1983
 Type: **Tapered inside**
Tapered outside (taper 1:16)
 Uses: Pipe threads, for pipe threads and fittings, sealing in the thread with sealing material

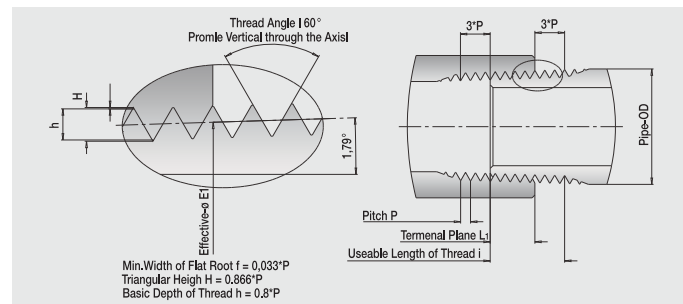

Inside NPT-thread

Nominal size	-54°C +20°C bar	psi	core ø
NPT 1/16"	450	6.525	6,00
NPT 1/8"	440	6.380	8,25
NPT 1/4"	450	6.525	10,70
NPT 3/8"	360	5.220	14,10
NPT 1/2"	330	4.785	17,40
NPT 3/4"	320	4.640	22,60
NPT 1"	300	4.350	28,50
NPT 1 1/4"	350	5.075	37,00
NPT 1 1/2"	310	4.495	43,50
NPT 2"	270	3.915	55,00

Outside NPT-thread

Nominal size	-54°C +20°C bar	psi	outside ø
NPT 1/16"	750	10.875	7,925
NPT 1/8"	690	10.005	10,287
NPT 1/4"	550	7.975	13,761
NPT 3/8"	540	7.830	17,145
NPT 1/2"	530	7.685	21,336
NPT 3/4"	500	7.250	26,670
NPT 1"	370	5.365	33,401
NPT 1 1/4"	410	5.945	42,164
NPT 1 1/2"	340	4.930	48,260
NPT 2"	270	3.915	60,325

Thread information

UNF Thread

Abbreviation: **UNF / UN**

Description: ANSI B 1.1 UNF 7/16-20

Type: **parallel inside** (Tol. 2 B) **parallel outside** (Tol.2 A)

Uses: Pipe fittings,
not sealing on the thread

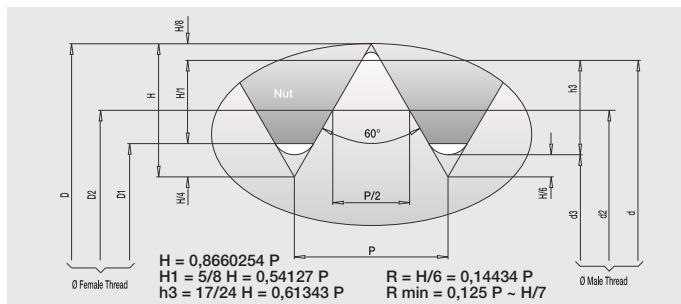

Inside UNF-thread

Nominal size	core ø
5/16 - 24	7,938
3/8 - 24	9,525
7/16 - 20	10,033
1/2 - 20	11,608
9/16 - 18	13,081
3/4 - 16	17,678
7/8 - 14	20,676
1 1/16 - 12	25,146
1 3/16 - 12	28,321
1 5/16 - 12	31,496
1 5/8 - 12	39,446
1 7/8 - 12	45,796

Outside UNF-thread

Nominal size	outside ø
5/16 - 24	7,938
3/8 - 24	9,525
7/16 - 20	11,079
1/2 - 20	12,667
9/16 - 18	14,252
3/4 - 16	19,012
7/8 - 14	22,184
1 1/16 - 12	26,944
1 3/16 - 12	30,119
1 5/16 - 12	31,496
1 5/8 - 12	41,229
1 7/8 - 12	47,579

Thread information

UNF Thread

**Parallel
Outside thread**

JIC 37°

Tube -54°C +20°C
bar

UNF 1/16"	340
UNF 1/8"	340
UNF 3/16"	340
UNF 1/4"	340
UNF 5/16"	310
UNF 3/8"	240
UNF 1/2"	210

Outside thread

SAE-OR

Nominal size UNF -54°C +20°C
bar

UNF 1/16"	310
UNF 1/8"	310
UNF 3/16"	310
UNF 1/4"	310
UNF 5/16"	310
UNF 3/8"	310
UNF 1/2"	310
UNF 3/4"	250
UNF 1"	200

Outside thread

SAE

Nominal size UNF -54°C +20°C
bar

UNF 1/8"	310
UNF 1/4"	310
UNF 5/16"	310
UNF 3/8"	310
UNF 1/2"	310
UNF 5/8"	250
UNF 3/4"	250
UNF 7/8"	200
UNF 1"	200
UNF 1 1/4"	160
UNF 1 1/2"	160
UNF 2"	120

Swiveling

SAE

Nominal size UNF -54°C +20°C
bar

UNF 1/8"	315
UNF 1/4"	315
UNF 5/16"	315
UNF 3/8"	315
UNF 1/2"	315
UNF 5/8"	250
UNF 3/4"	250
UNF 7/8"	200
UNF 1"	160
UNF 1 1/4"	120
UNF 1 1/2"	120
UNF 2"	100



Chemical Composition



Material	Schwer	Type	Cr	Ni	Mo	C	Si	Mn	S	N	Cu	Ti	Al
1.4034			12,50-14,50			0,43-0,50				<0,030			
1.4104	1		15,50-17,50		0,20-0,60	0,10-0,17				0,15-0,35			
1.4122			15,50-17,50	max. 1,00	0,80-1,30	0,33-0,45							
1.4301	2	A2	17,50-19,50	8,00-10,50		max. 0,07							
1.4305	05	A1	17,00-19,00	8,00-10,00		>0,10	<1,00	<2,00	0,15-0,35	<0,11			
1.4306	2L	A2	18,00-20,00	10,00-12,00		max. 0,03							
1.4401	4L	A4	16,50-18,50	10,00-13,00	2,00-2,50	max. 0,07							
1.4404	4L	A4	16,50-18,50	10,50-13,00	2,00-2,50	max. 0,03							
1.4408	08	A4	16,50-18,50	10,50-13,50	2,0-2,5	max. 0,07	1	max. 2,0					
1.4462	DX	A4	21,00-23,00	4,50-6,50	2,50-3,50	max. 0,03				0,10-0,22			
1.4435	5	A4	17,00-18,00	12,50-13,50	2,50-3,00	max. 0,03							
1.4541	3	A3	17,00-19,00	9,00-12,00		max. 0,08							<5xC max. 0,70
1.4571	7	A4	16,50-18,50	10,50-13,50	2,00-2,50	max. 0,08		<2,00					5xC max. 0,70
1.4539	39	A4	19,00-21,00	24,00-26,00	4,00-5,00	max. 0,02					1,20-2,00		
1.4568		A4	16,00-18,00	6,50-7,80		max. 0,09		max. 1,0					0,70-1,50

International

Material	Schwer	Type	short name DIN	stainless, acid, heat-resistant	steel structure	Stainless Steel AISI	France AFNOR	England BS	Italia UNI	SIS Sweden	JIS Japan
1.4034			X46Cr13	Corr. res. stainless	Martensitic	420	Z44C14/Z38C13	420S45			
1.4104	1		X14CrMoS17	Stainless	Ferrit	430F	Z13CF17			2383	SUS430F
1.4122			X39CrMo17-1	Chrome-steel	Martensitic						
1.4301	2	A2	X5CrNi18-10	Stainless	Austenite	304	Z7CN18-09	SUS304	X5CrNi1810	2333	SUS304
1.4305	5	A1	X8CrNi18-9	Stainless	Austenite	303	Z8CNF18-09	303S22	X10CrNiS18-09	2346	SUS303
1.4306	2L	A2	X2CrNi19-11	Investment casting	Austenite	304L	Z2CN18-10	304S11	X2CrNi1811	2352	SUS304L
1.4401	4	A4	X5CrNiMo17-12-2	Stainless	Austenite	316	Z7CND17-11-02	316S17	X5CrNiMo17-12	2347	SUS316
1.4404	4L	A4	X2CrNiMo17-12-2	Stainless	Austenite	316L	Z3CND17-11-02	316S11	X2CrNiMo17-12		SUS316
1.4408	8	A4	G-X6CrNiMo18-10	Investment casting	Austenite	316	Z6CND17-11				
1.4462	DX	A4	X2CrNiMoN22-5-3	Duplex steel	Austenite	329	Z3CND22-05 Az	318S13		2377	SUS329J3L
1.4435	5	A4	X2CrNiMo18-14-3	Stainless	Austenite	316L	Z3CND17-12-03	316S11	X2CrNiMo1713	2353	316
1.4541	3	A3	X6CrNiTi18-10	Stainless	Austenite	321	Z6CNT18-10	321S31	X6CrNiTi1811	2337	SUS321
1.4571	7	A4	X6CrNiMoTi17-12-2	Stainless	Austenite	316Ti	Z6CND17-12	320S31	X6CrNiMoTi17-12	2350	SUS316Ti
1.4539	39	A4	X2NiCrMoCu25-20-5	Duplex	Super Austenite	904L	Z2NCUDU25-20			2562	
1.4568	5F	A4	X 7 CrNiAl 17 7	Spring steel	Austenite	631					SUS631



Materials



Materials

-4	= 1.4401 AISI 316	-C20	= Alloy 20
-4L	= 1.4404 AISI 316L	-C6	= 2.4819 Hastelloy C-276
-5	= 1.4435	-INC	= Inconel 2.4816 Alloy 600
-7	= 1.4571 AISI 316Ti	-Mo	= Monel Alloy 400
-A	= Aluminium	-S	= Steel
-B	= Brass	-DX	= Duplex 1.4462
-C4	= Hastelloy	-SDX	= Super Duplex 1.4410
-C22	= Hastelloy	-TI	= Titan 3.7035

Further Materials on request.

Gaskets:

The following charts show the abbreviations according to ISO 1629 and ASTM 1418, the temperature range, the chemical description, some trade names, essential qualities of those gasket materials normally used, as well as the compatibility with several media.

Abbreviation	Temperature range	Chemical description
NBR	-30° C to 100° C	Acrylonitrile-Butadiene-Elastomer
EPDM	-50° C to 150° C	Ethylene-Propylene-Diene-Elastomer
VMQ (MVQ)	-40° C to 200° C	Silicone-Elastomer
FKM	-20° C to 200° C	Fluoro-Elastomer
PTFE	-200° C to 230° C	Polytetrafluoroethylene

Abbreviation	Trade names
NBR	Perbunan, Buna, Baypren, Hycar, Breon, Butakon
EPDM	EPDM, Dutral, Keltan, Vistalon, Nordel, Epsyn
VMQ (MVQ)	Silicone, Silastic, Silopren, Rhodorsil
FKM	Viton, Fluorel, Tecnoflon, Noxtite, Dai El
PTFE	Teflon, Halon, Hostaflon, Algoflon, Fluon

Material properties:

Grading: 1 = very good, 2 = good, 3 = satisfying, 4 = sufficient, 5 = deficient, 6 = insufficient

	NBR	EPDM	VMQ	FKM	PTFE
Aging resistance	3	1	1	1	1
Ozone resistance	3	1	1	1	1
Petrol resistance	1	5	5	1	1
Oil and fat resistance	1	4	1	1	1
Acid resistance	4	1	5	1	1
Alkali resistance	3	2	5	1	1
High temp. water res.	3	2	5	2	1
Steam resistance	6	1	4	6	2
Gas impermeability	3	2	2	2	5
Abrasion resistance	2	3	5	4	3
Electric resistance	4	2	1	4	1

Training

Schwer Fittings is a BFPFA training centre. The training courses below take place at our facility in Warrington, Cheshire. For more information visit www.schwer.co.uk or www.bfpa.co.uk.

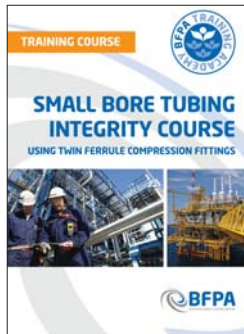
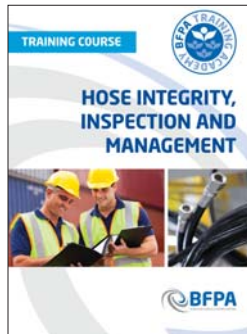
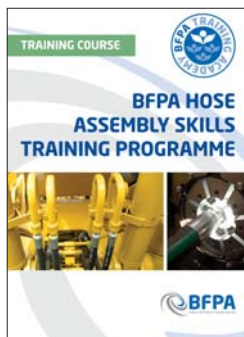
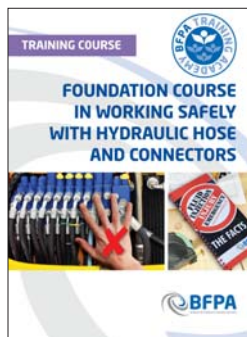

Information

Online-Shop

Visit our eShop at www.schwer.com for orders, enquiries, and additional technical information.

eShop: www.schwer.com



General Information

Also available from Schwer Fittings:

- Screwed Fittings, Hose Stems
- Interchangeable Pipe Fittings
- Aquapress Press Fittings
- Soldering Fittings and Equipment
- Flare Couplings
- 24° Cone Sealing Couplings
- Valves: -Needle, Ball, Gate, Shut-off
- Ball Valves, Actuator
- Push-In Fittings, Push-On Fittings
- 24° Compression Fittings
- Rotary-Swivel Joint
- Non Return Valves
- Quick Couplings
- Solder Nipples
- 60° coned Hydraulic Adapters
- Flow Meters, Gauges, Thermometers
- Pressure Gauge Connectors
- Stainless Steel Tube
- Welding Fittings
- Flanges
- Pipe Clamps, Mounting Rail
- 24° Weld Nipples
- Orbital Welding-Fittings
- Hose Fittings, Hoses
- Cam Lock Couplings
- Tube Couplings
- 37° JIC Fittings
- Special Parts, Custom-made Items
- Auxiliary Materials, Accessories
- Assembly aids and tooling
- Instrumentation:**
- u2-Twin Ferrule Fittings
- Clino Aseptic Clamp Fittings
- VC and Orbital Welding Fittings

© Schwer Fittings GmbH 2016. Reproduction in any form, wholly or in part, is only allowed with prior permission. Contents subject to change without notice.

Focus in details[®]



For the most up to date version of this documentation please go to www.schwer.co.uk.



You can find all our assembly instructions
on our website:

www.schwer.com

schwer.com

schwer fittings

Schwer Fittings Ltd.
Unit 20
Wharf Employment Area Howley
Warrington Cheshire WA1 2HT

Tel.: +44 (0)19 25 63 90-06
Fax: +44 (0)19 25 63 90-07
info@schwer.co.uk
www.schwer.co.uk